

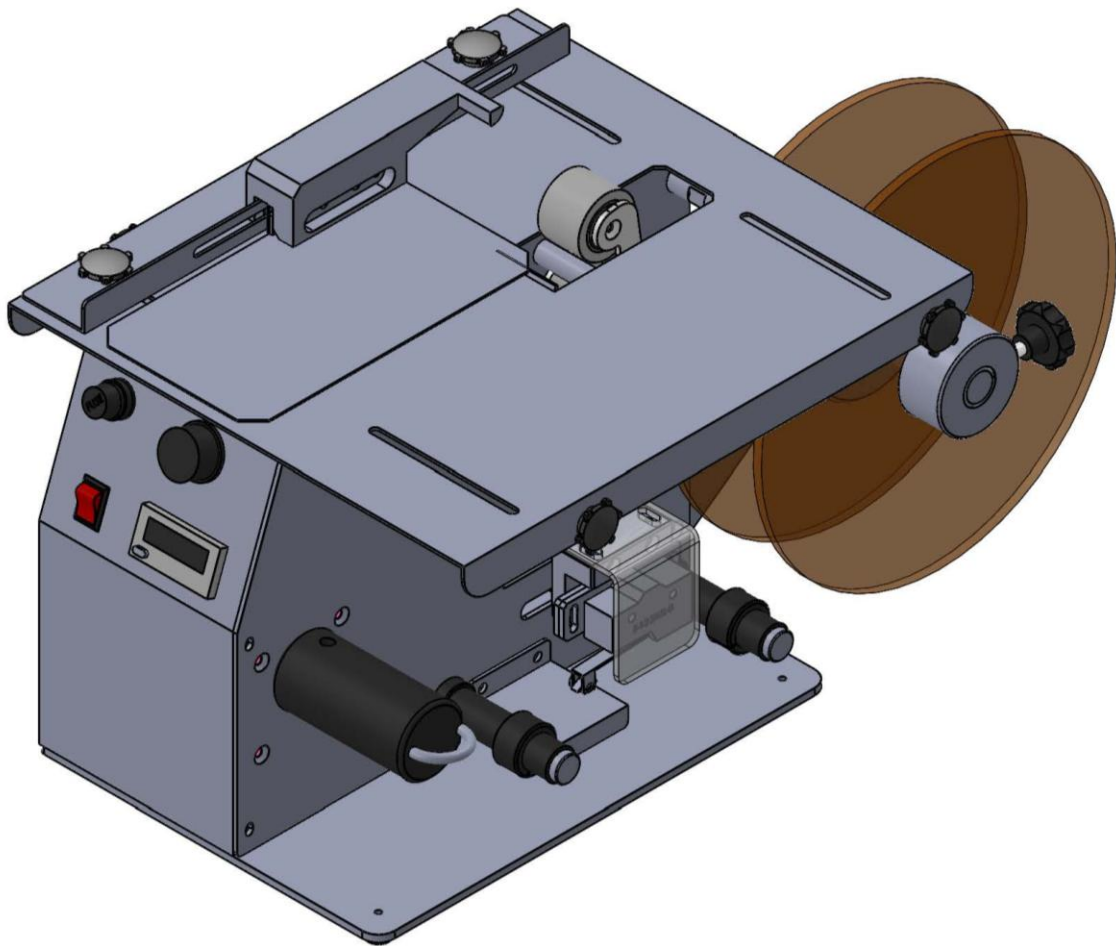

02 9452-3566

sales@getpacked.com.au

Clip Label Applicator Manual



Model : CKF-105

Voltage : AC240V/50HZ

Table Of Contents

I. Introduction

- A. Major Components
- B. Control Panel
- C. Precautions

II. Label Threading Diagram

- A. Winding Direction
- B. Replace The Label Roll

III. Adjustment Instructions

- A. Adjustment Method



I. Introduction

A. Major Components :

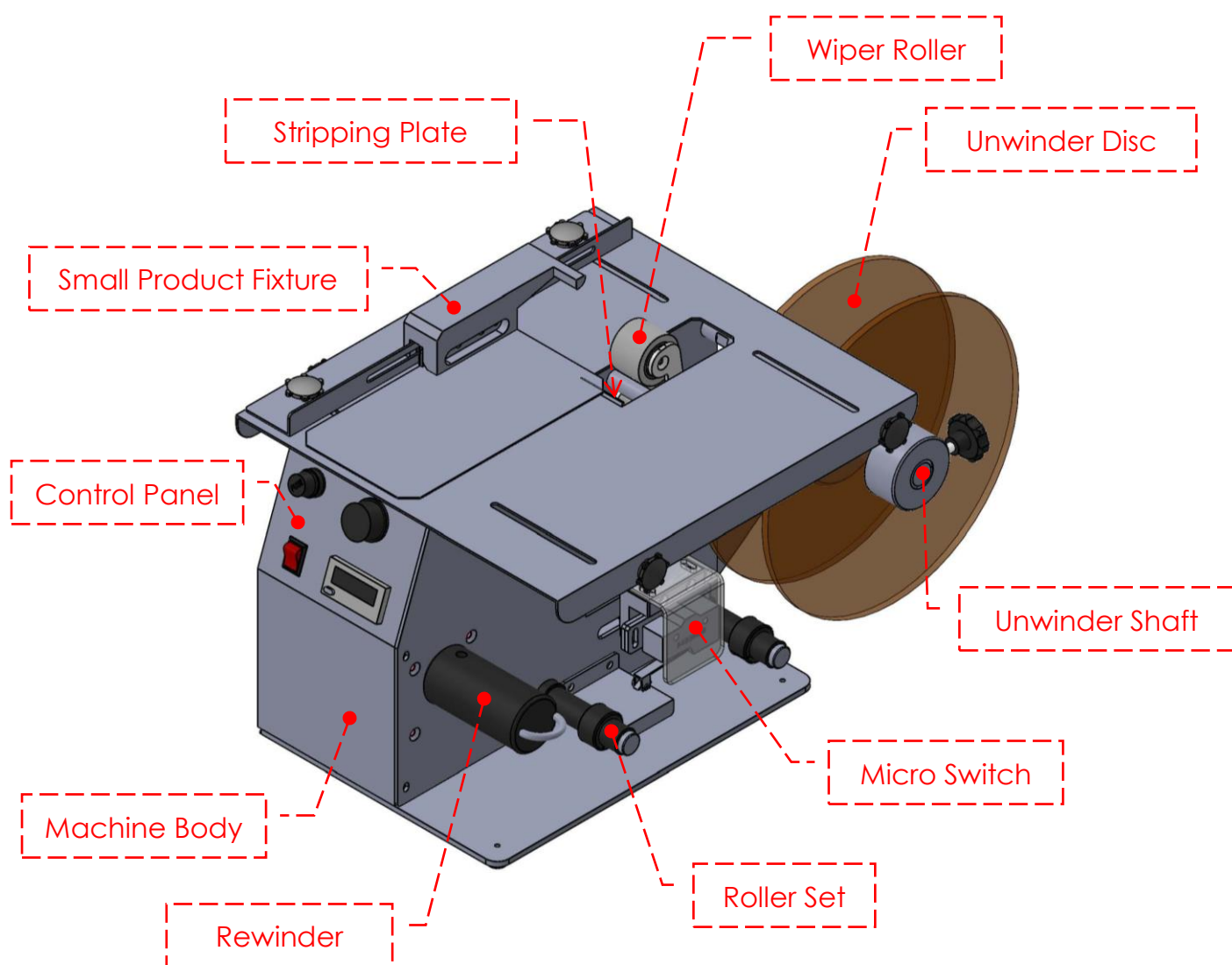

* Specification :

- Label Length : 15 ~ 50 mm
- Label Width : 10 ~ 50 mm
- Paper Coil Inside Diameter : 1" ~ 3"
- Label Roll Outside Diameter : < $\text{Ø}200$ mm
- Power Supply : AC240V/50HZ
- Machine Dimension : L500 mm × W285 mm × H290 mm
- Net Weight : 10.5 kg

B. Control Panel :

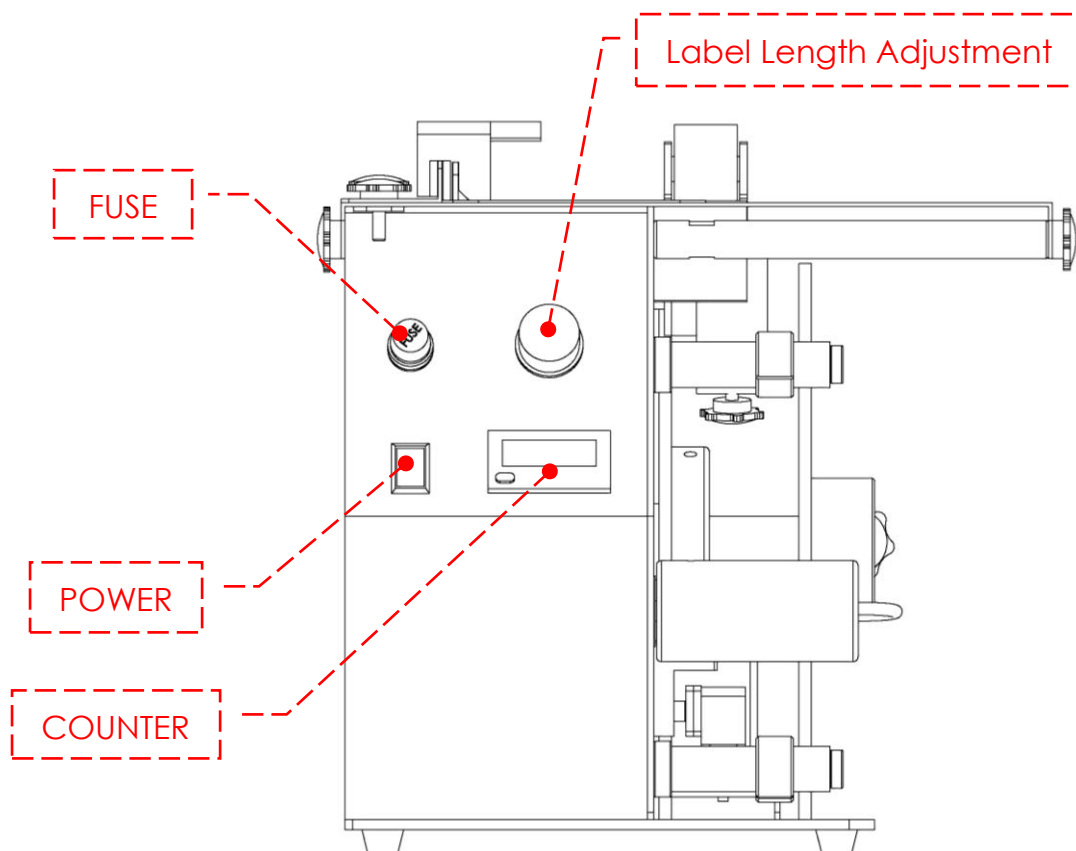

C. Precautions :

- (a) Do not touch the micro switch while the machine is in operation.
- (b) If the label feeds continuously, adjust the micro switch to the right angle.



II. Label Threading Diagram

A. Winding Direction :

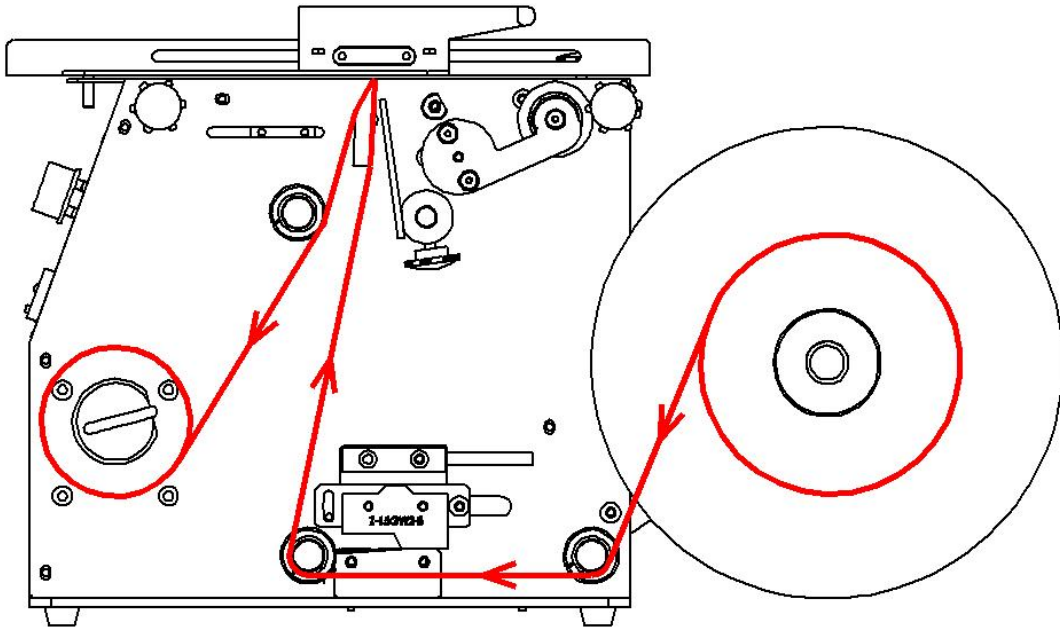

B. Replace The Labelroll :

- (a) Loosen the handle.
- (b) Remove the unwinder disc.
- (c) Replace a new label roll.
- (d) Fix unwinder disc.
- (e) Lock the handle.



III. Adjustment Instructions

A. Adjustment Method :

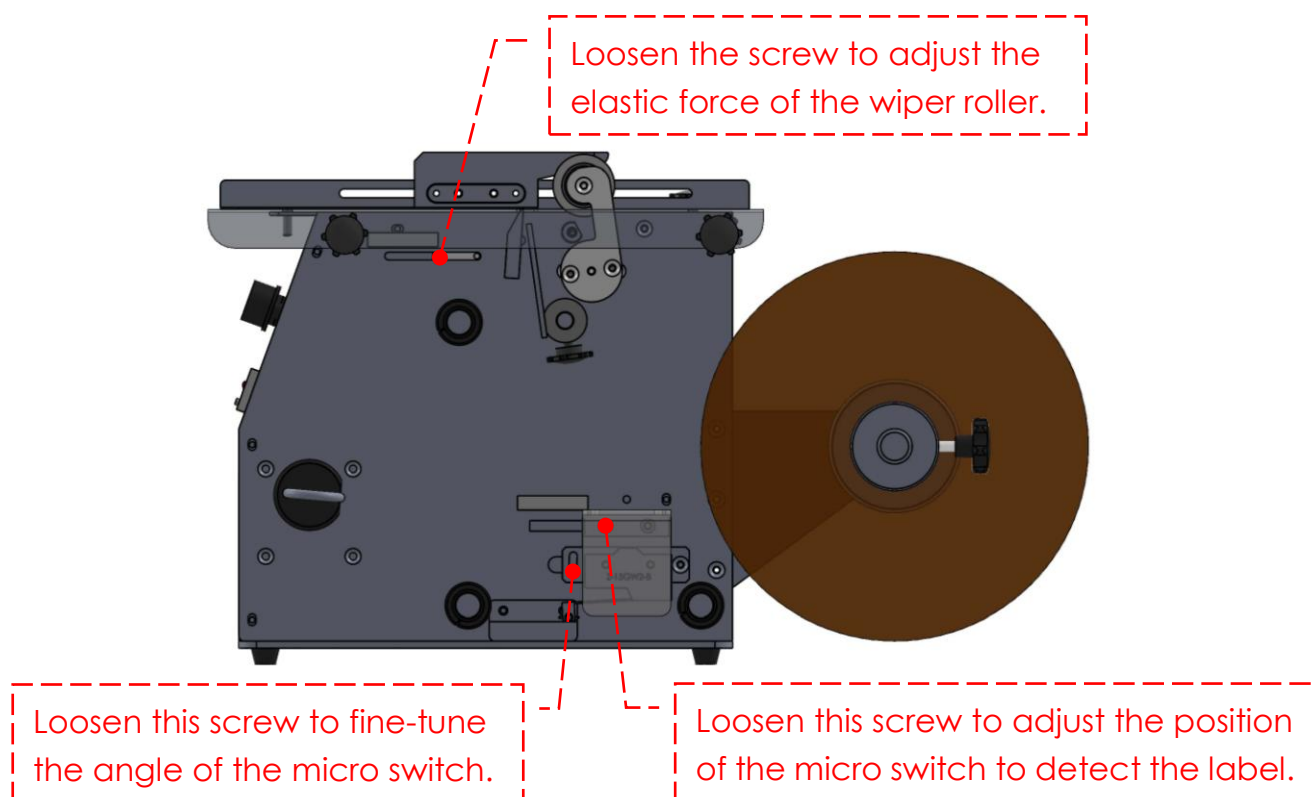
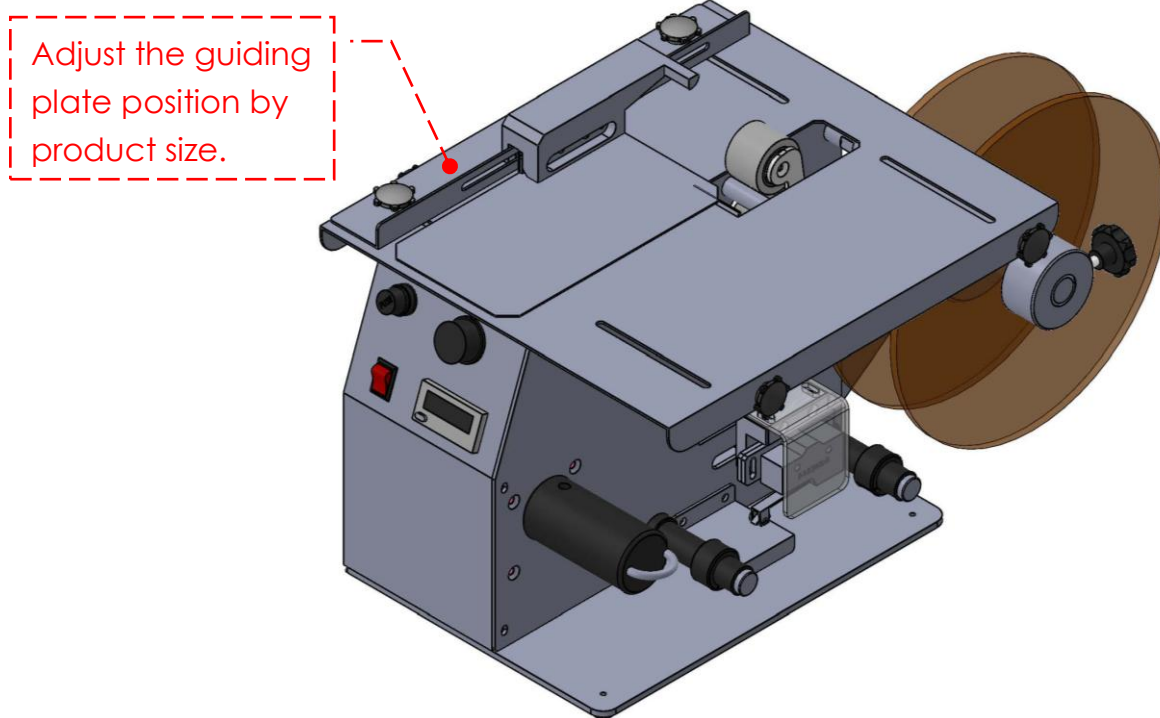

*** Lock the screws after adjustment.**