

CASE SEALING MACHINE

MODEL: EXC-103TB

OPERATION MANUAL

2009/05/15

1. GENERAL

- 1.1 Notice of installment 2
- 1.2 Notice of operation 2

2. SPECIFICATION

- 2.1 Spec. table 3
- 2.2 Machine dimension 4
- 2.3 Machine description. 5

3. OPERATION DESCRIPTION

- 3.1 Installment 6
- 3.2 Operation of control panel 9

4. COUNTER INSTRUCTION 10

5. ELECTRIC

- 5.1 Electric capacity 10
- 5.2 Electric diagram 11

6. TROUBLE SHOOTING

- 6.1 Belt adjustment 15
- 6.2 Fuse replacement 15

7. PARTS LIST

- 7.1 Upper taping seat 16
- 7.2 Column. 19
- 7.3 Under taping seat 21
- 7.4 Machine body 24

1. GENERAL

1.1 Notice of installment

To make sure of a safe and correct operation, please check the below items before installing the machine:

- 1) Power source capacity must be larger than the machine need.
- 2) A shorter ground wire is better.
- 3) Machine standard power is 110V/220V (-15% - +10%).
- 4) Machine standard power Hertz is 50/60 Hz. ($\pm 2\%$)
- 5) Machine is good between temperatures 0°C - 45°C .
- 6) Any thing/substance around the machine should not produce loud noise and vibration.

1.2 Notice of operation

To have good protection for the operator, please make sure of the following conditions:

- 1) Before operating, please read the machine manual carefully.
- 2) Make sure no good have been put on the power cable.
- 3) Make sure no goods been have put on the upper tape head unit.
- 4) Don't allow damp parts or water to touch the electric parts.

2. SPECIFICATION

2.1 Spec. table

model	EXC-103TB
Tape	36mm(1.5") or 50mm(2")
Belt speed	23m/min
Capacity	(L) 120mm~unlimited (W) 140mm~500mm (H) 120mm~500mm
Consumption	450W
Machine size	1637mm(L) x 754mm(W) x 1375mm(H)
Sound level	60dB
Machine net weight	153KG

Standard option:

- Stainless plant
- 3" tape head
- CASE SIZE : 700mm(W) X 700mm(H)

2.2 Machine dimension

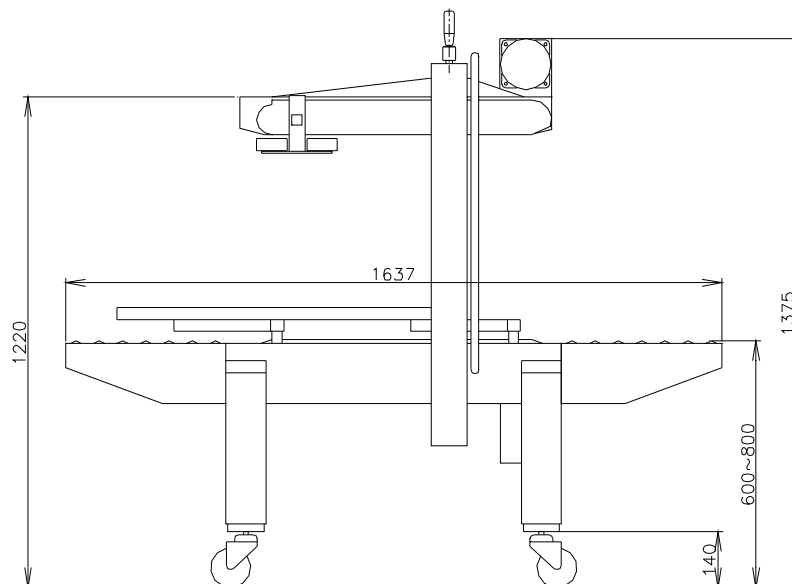
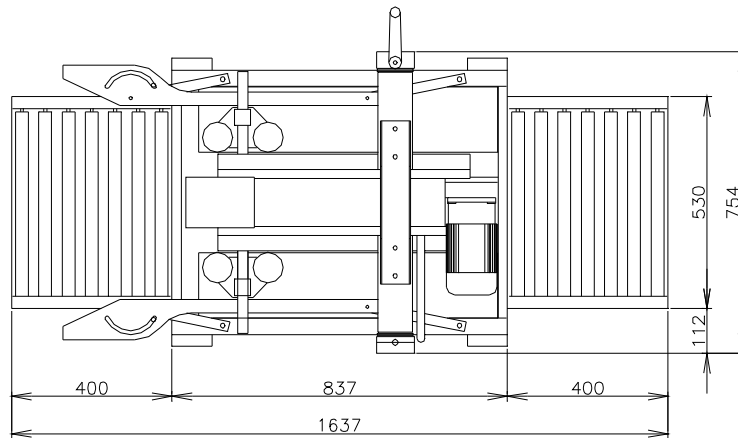

EXC-103TB

2.3 Machine description

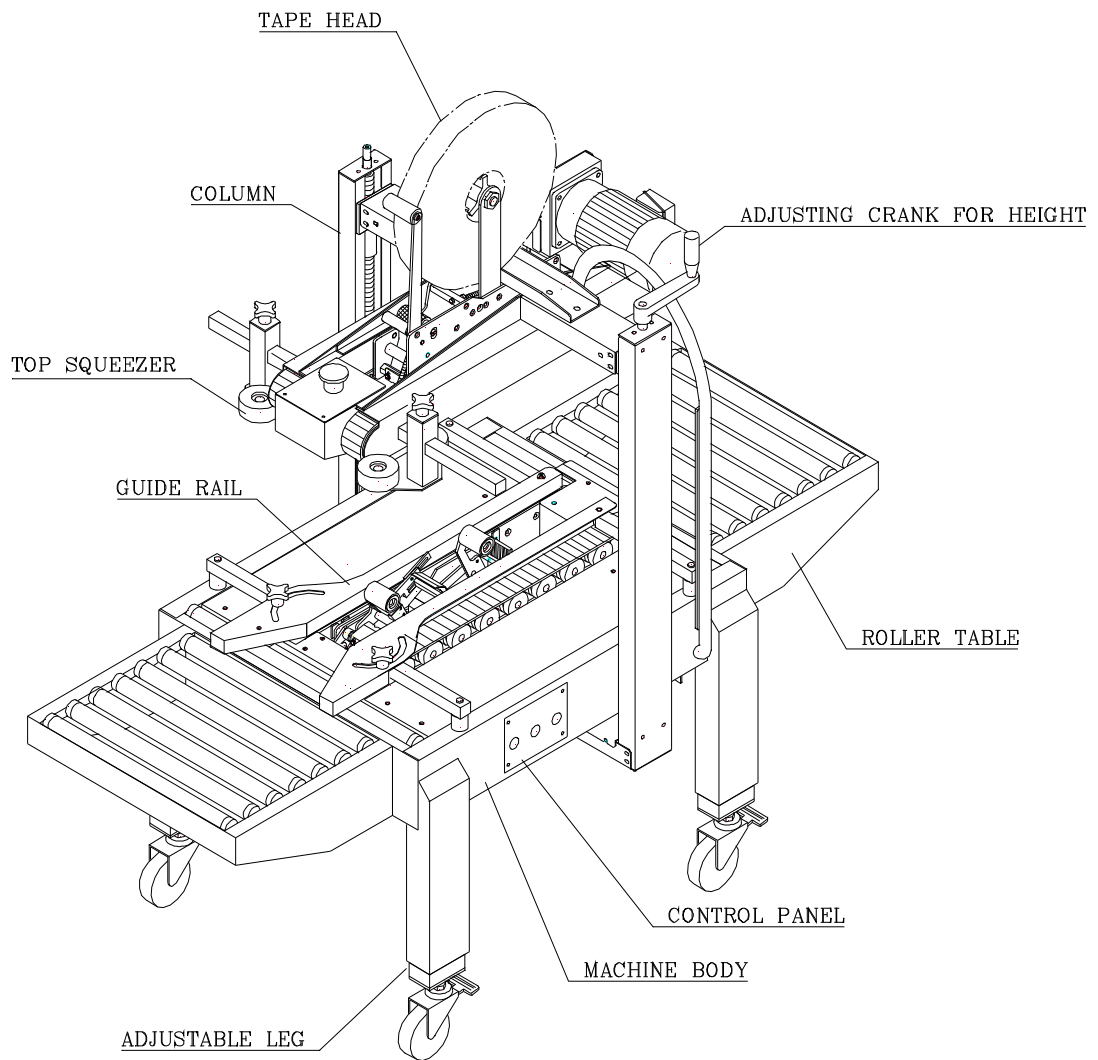

3. OPERATION DESCRIPTION

3.1 Installment

- 1) Open the box. Please remove carefully to avoid damaging the machine.
- 2) Lift the machine to install casters (4 wheels), at the same time tighten the A nut to fix the casters in place.
- 3) Set the machine to the desired height, then tighten the B screw.

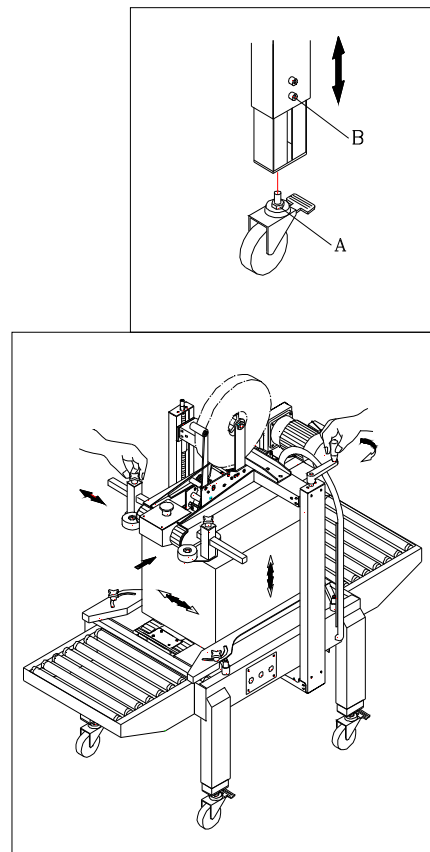

- 4) Set up the machine and move to the desired place.

5) Attach the roller table to the machine body.

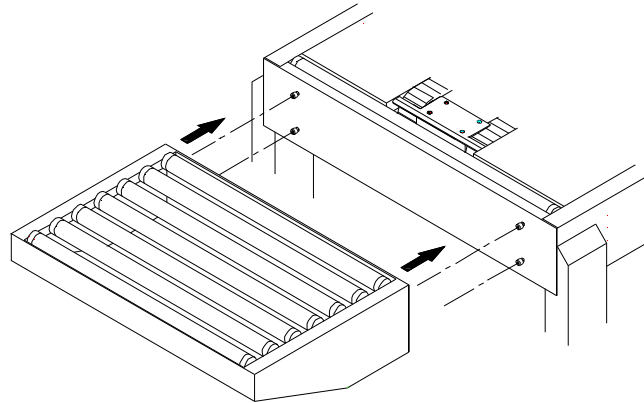

6) Load the tape head with tape. (Please refer to the tape head instruction manual)

7) Place a box filled with product on the in feed conveyor, position on the side drive belts and top section to accommodate the desired box width and height by using the width and height adjustment crank.

Follow by adjusting the tow handle knobs against the sides of carton to secure the carton's center.

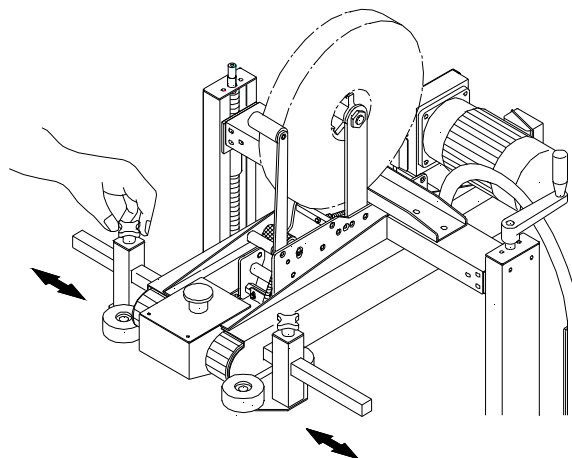

- 8) Connect the power cable with the socket to a 110V/220V power source.
- 9) Plug in, press "start" button for testing.

3.2 OPERATION OF CONTROL PANEL

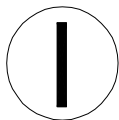
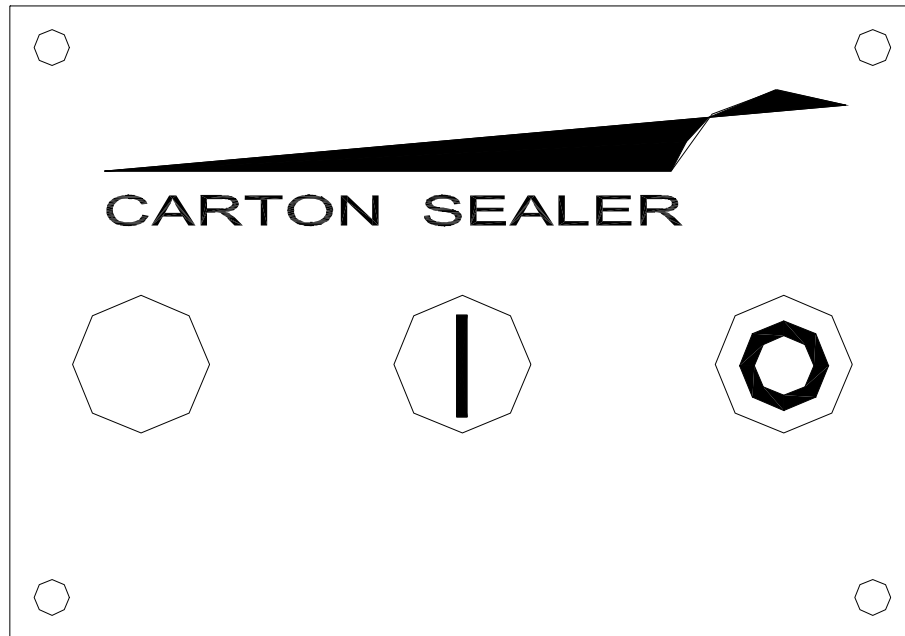

Press to start motors and belts.

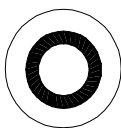

Press to stop motors and belts.

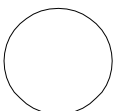

Power indicator will be off; when carton sealer is in operation.

Power indicator will be on: when carton sealer is not in operation.

4. COUNTER INSTRUCTION

1. It is forbidden to cancel, disassemble, modify or not respect the implemented safety measures. In that case, the manufacturer will not be hold responsible for any possible damage caused.
2. Do not use the machine in a place where water and oil might splash
3. Use only the specify power supply cable
4. Do not pull the power supply cable to move the machine. It will damage or break the cord
5. Do not use the machine in any way which is not specified in this manual
7. It is forbidden to exceed the limits of use and operation on what regards weights and sizes of loads.
8. It is forbidden to use the machine with unstable loads which show hazard of falling.

5 . ELECTRIC

5.1 Electric capacity

1)Power consumption

Belt motor	0.18KVA	
Machine power use	0.4KVA	
Power socket need	0.5KVA	

2)Power cable 1.25mm²

3)Machine input AC 110V/220V 1-Phase

5.2 Electric diagram

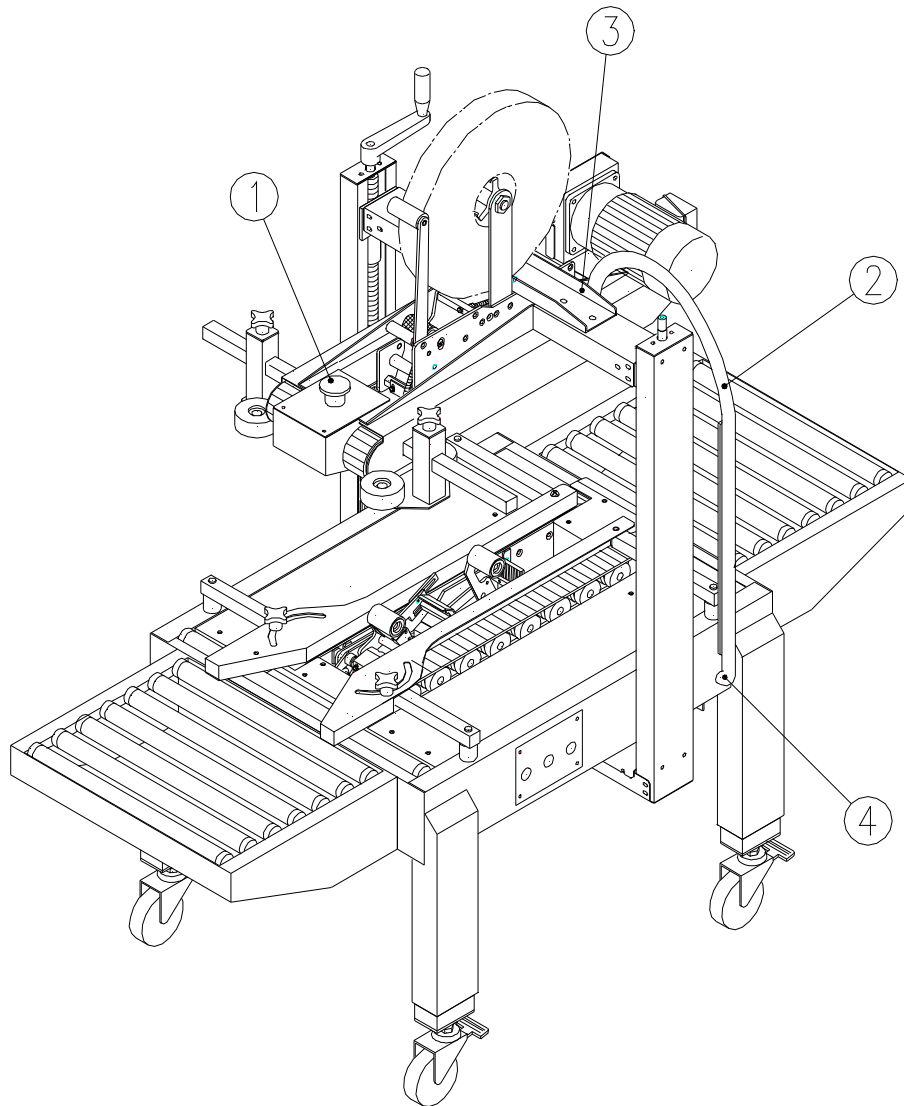

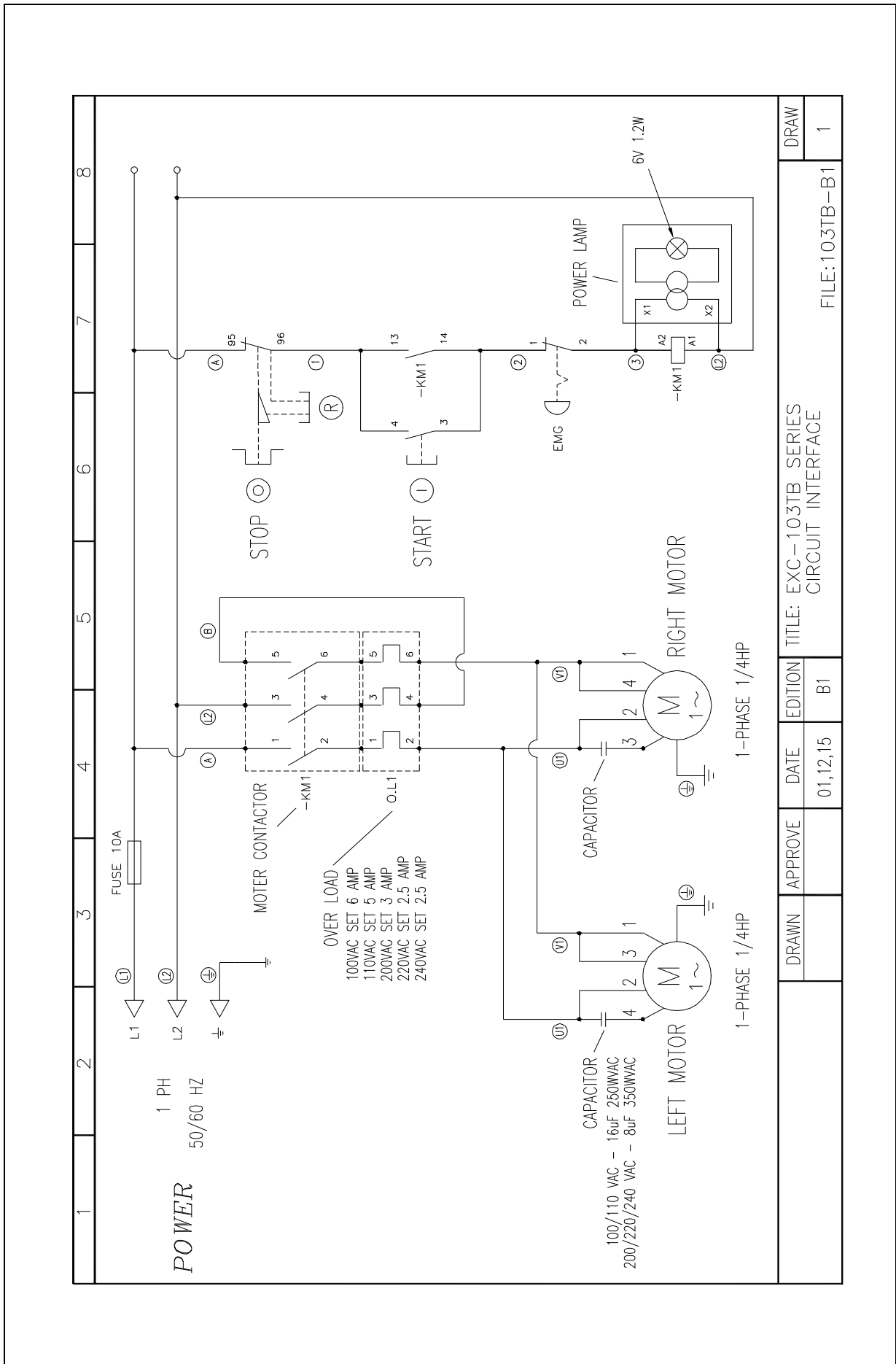

DRAWN			DRAW		
APPROVE			FILE:103TB-B1		
DATE			TITLE: EXC-103TB SERIES		
EDITION			CIRCUIT INTERFACE		
01,12,15			B1		
DRAWN			1		

ELECTRIC PARTS LIST FOR EXC-103TB

KEY NO	PART NO.	DESCRIPTION	Q'TY
1	7155BC01	EMG. SWITCH	1
	7158BZ02	BUTTON SEAT CONTACTOR NCx1	1
2	7066P001	1/2" CONNECTOR	1
3	7065C062	1/2" PROTECT TUBE	1
4	7066C064	1/2" 90° CONNECTOR	1
11	70560601	TERMINAL BLOCKS TB6P	1
12	7032SW01	CONNECTOR	1
13	71570002-01	BREAKER LC1-D09F7 110V	1
	71570003-01	BREAKER LC1-D09M7 220V	1
14	71570002-02	OVERLOAD PROTECTOR LR3-D106(4-6A)	1
	71570003-02	OVERLOAD PROTECTOR LR3-D086(2.5-4A)	1
15	7155AL01	BUTTON	1
16	7155AA03	BUTTON	1
	7158AZ01	CONTACTOR NOX1	1
17	7151AV01	POWER LAMP 220V	1
	7150AV01	BLANKIG PLUG	1
	7151AV02	POWER LAMP 110V	1
	7150AV01	BLANKIG PLUG	1
18	7025AG16	FIXED SEAT	4
19	72561003	FUSE	1
	7250FH01	FUSE SEAT	1
20	7155AL01-1	ENCLOSURE	1

6. TROUBLE SHOOTING

6.1 Belt adjustment

- 1) loosen the belt nut (A) to adjust the belt to a suitable tension (B).

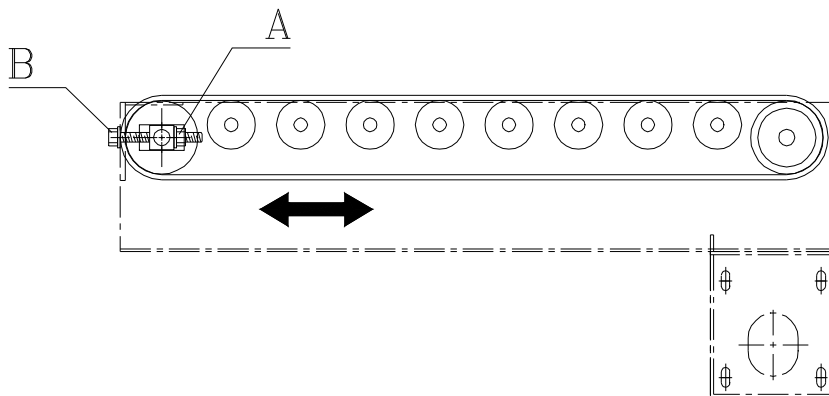

6.2 Fuse replacement

Symptom: machine will not start to operate.

- (a) Please check the power input.
- (b) Release the E-stop button.
- (c) Press start button to release over load.
- (d) Check to see if the fuse is in good condition. If faulty, replace with new fuses as shown in the diagrams.
- (e) Confirm the steps above and re-start the machine.

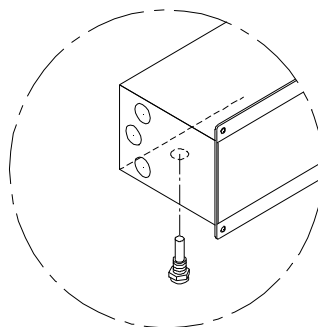

7. PART LIST

7.1 Upper taping seat

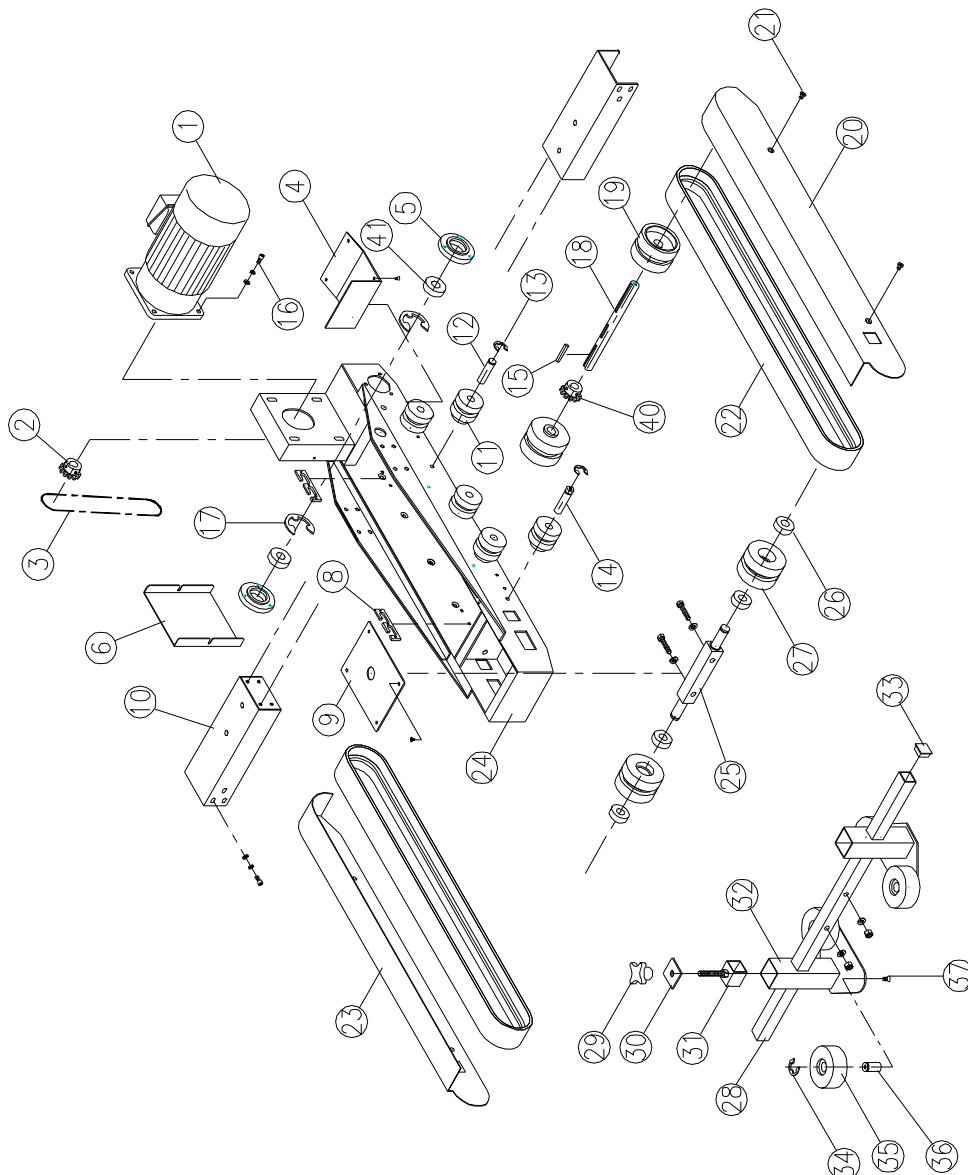

PARTS LIST FOR EXC-103TB

KEY NO	PART NO.	DESCRIPTION	Q'TY
1	745111L1	MOTOR 110V/60HZ,T18:1	1
	745122L1	MOTOR 220V/60HZ,T18:1	1
	745122L2	MOTOR 220V/50HZ,T15:1	1
	745124L2	MOTOR 240V/50HZ,T15:1	1
	745138L1	MOTOR 380V/50HZ,T15:1	1
	745140L1	MOTOR 400V/50HZ,T15:1	1
	2	CA331200	MOTOR SPROCKET WHEEL
3	3240S35C	CHAIN	1
4	CA130600	COVER PLATE (2")	1
	CA130610	COVER PLATE (3")	1
5	CA131000	BEARING SEAT	2
6	CA331100	MOTOR COVER	1
7			
8	CA100300	B-PLATE	4
9	CA130300	COVER PLATE (2")	1
	CA130310	COVER PLATE (3")	1
10	CA130200	SUPPORT SET (2")	2
	CA130210	SUPPORT SET (3")	2
11	CA301300	PLASTIC PULLEY	10
12	CA301400	PULLEY SHAFT	6
13	11301200	RING STW-12	10
14	CA130700	PULLEY SHAFT	4
15	10925300	KEY	1
16	10100825	SCREW M8*25L & S.W & W	4
17	11314000	RING RTW-40	2
18	CA331400	DRIVER SHAFT(2")	1
	CA331410	DRIVER SHAFT(3")	1
19	CA301900	PULLEY DRIVER	2
20	CA1312R0	BELT COVER	1
21	10200610	SCREW M6*10L & S.W & W	4
22	CA331900	BELT	2
23	CA1312L0	BELT COVER	1
24	CA13010A	UPPER TAPING SEAT (2")	1
	CA130110	UPPER TAPING SEAT (3")	1
25	CA330800	ADJUSTABLE SHAFT(2")	1
	CA330810	ADJUSTABLE SHAFT(3")	1
26	30300030	BEARING 6003ZZ	4

S.W:SPRING WASHER

W:WASHER

7.2 Column

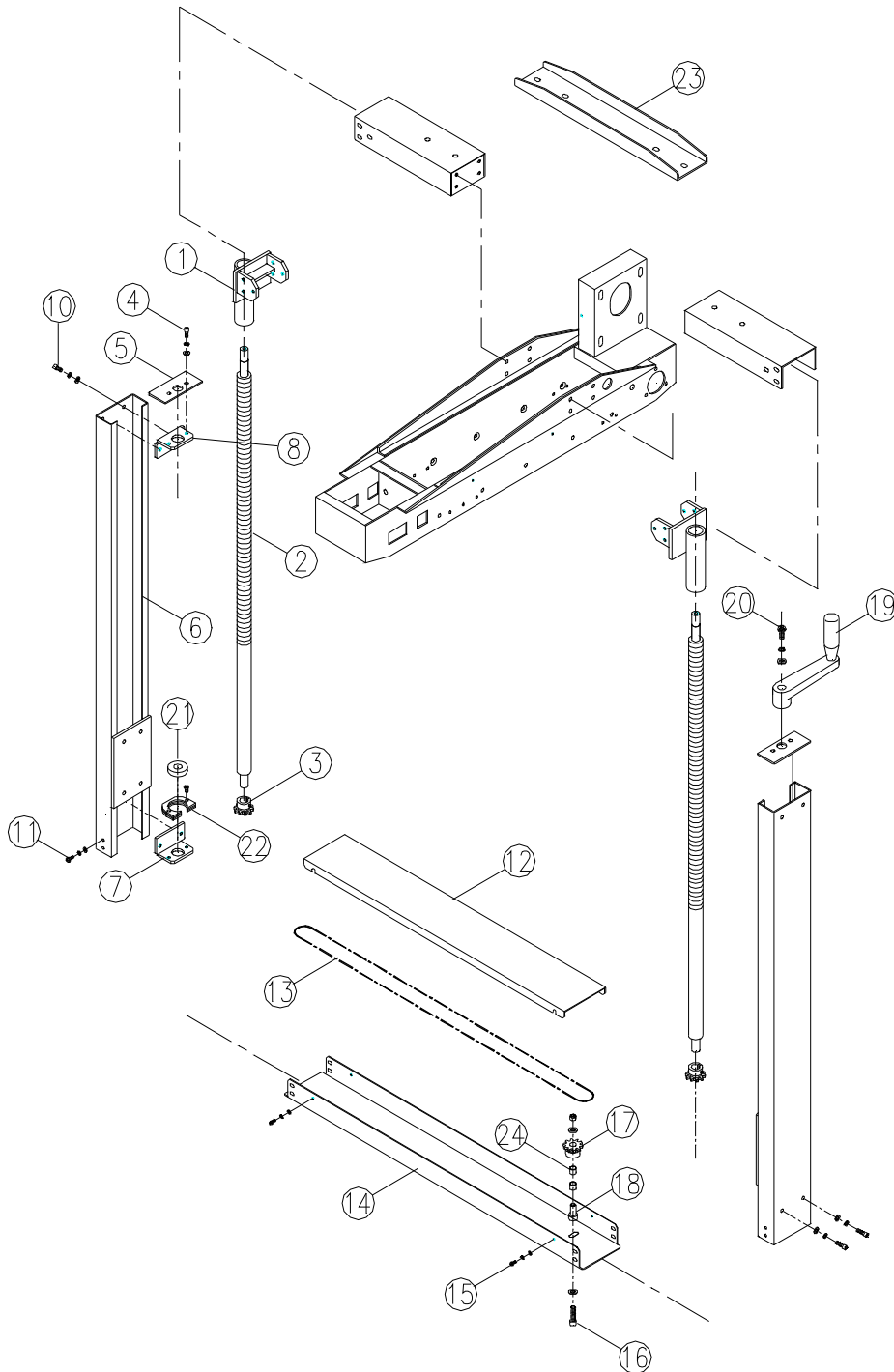

7.3 Under taping seat

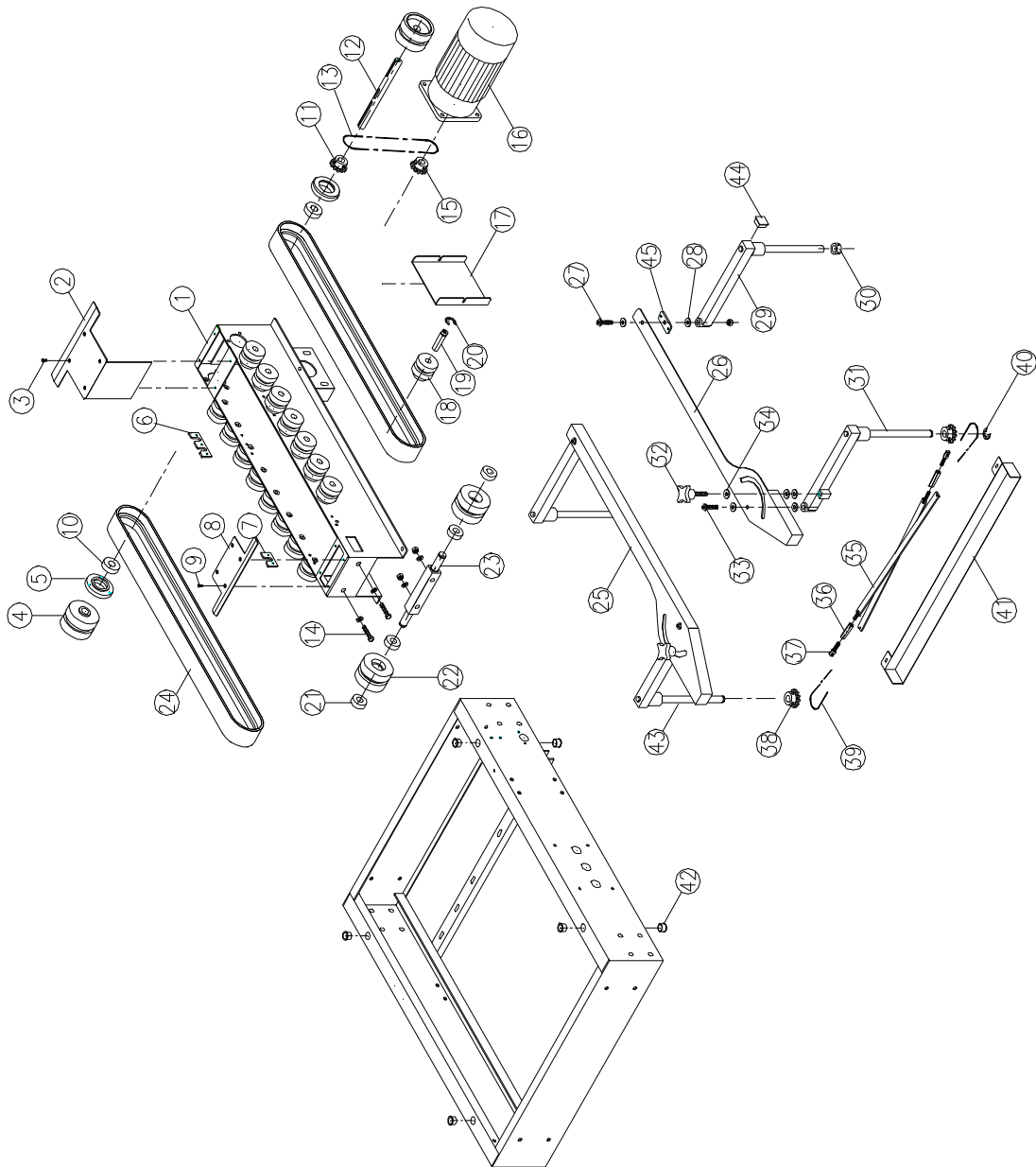

PARTS LIST FOR EXC-103TB

KEY NO	PART NO.	DESCRIPTION	Q'TY
1	CA330200	UNDER TAPING SEAT (2")	1
	CA330210	UNDER TAPING SEAT (3")	1
2	CA332200	COVER (2")	1
	CA332210	COVER (3")	1
3	10140406	SCREW M4*6L	4
4	CA301900	PULLEY DRIVER	2
5	CA131000	BEARING SEAT	2
6	CA33070A	B-PLATE	2
7	CA33060A	A-PLATE	2
8	CA331700	COVER (2")	1
	CA331710	COVER (3")	1
9	10140406	SCREW M4*6L	4
10	30302030	BEARING 6203ZZ	2
11	CA331300	MOTOR SPROCKET WHEEL	1
12	CA331400	DRIVER SHAFT (2")	1
	CA331410	DRIVER SHAFT (3")	1
13	3240S357	CHAIN	1
14	10110870	SCREW M8*70L & NUT	2
15	CA331200	MOTOR SPROCKET WHEEL	1
16	745111M1	MOTOR 110V/60HZ,T18:1	1
	745122M1	MOTOR 220V/60HZ,T18:1	1
	745122M2	MOTOR 220V/50HZ,T15:1	1
	745124M2	MOTOR 240V/50HZ,T15:1	1
	745138M1	MOTOR 380V/50HZ,T15:1	1
	745140M1	MOTOR 400V/50HZ,T15:1	1
17	CA331100	MOTOR COVER	1
18	CA301300	PLASTIC PULLEY	16
19	CA301400	PULLEY SHAFT	16
20	11301200	RING STW-12	16
21	30300030	BEARING 6003ZZ	4
22	CA301100	PULLEY FOLLOWER	2
23	CA330800	ADJUSTABLE SHAFT (2")	1
	CA330810	ADJUSTABLE SHAFT (3")	1
24	CA331900	BELT	2
25	CA3303L0	GUIDE RAIL	1
26	CA3303R0	GUIDE RAIL	1
27	10200840	SCREW M8*40L & NUT	2

S.W: SPRING WASHER W: WASHER

7.4 Machine body

